



凱華電子
KAIHUA EEELETRONICS

Document Number:

KH-PS1905-24

For reference

产品规格书

Product Specification

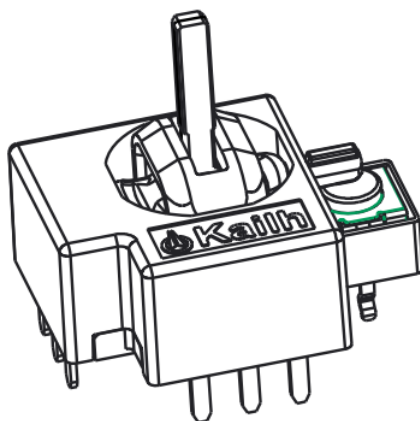

JP1275 Joystick (With Switch)

P/N: CJP127519D03-B			Title : Joystick		
Rev.	ECN	Release and Revision Description:	Prepared By/Date:	Checked By/Date:	Approved By/Date:
A	— —	New releasing 初版发行	张林/2019.05.28	张林/2019.05.28	王锋/ 2019.05.28



For reference

Content

目录

1. Scope/范围:.....	3
2. Product Application/产品应用 :	3
3. Technology Parameters/技术参数	3
4. Ratings/额定性能要求.....	3
5. Profile Dimensions /外形尺寸.....	4
6. Electrical Performance/电气性能	4
7. Switch characteristics 开关性能 (For with-switch type)	4~6
8. Mechanical Performance/机械性能.....	6~7
9. Environmental Performance/环境性能.....	7~8
10. Recommended PCB Layout/推荐的 PCB 安装焊盘规格	8~10
11. Prackaging/包装	10~11
12. Precaution/注意事项	11~12



1. Scope/范围:

This product specification covers the requirement of joystick which carbon composition resistor on product performance, test methods and quality assurance provisions.
 本规格书涵盖合成碳膜电阻摇杆产品的要求，包括性能指标、测试方法及质量保证方面等。

2. Product Application/产品应用:

The Joystick is applied in all types of games handle and portable game system. Please let us know before using any of the products in the application not described above.
 该摇杆产品适用于所有类型的游戏手柄和便携式游戏系统。如果用于本文中未提及的领域请在使用前告知。

3. Technology Parameters/技术参数

Ambient Humidity 工作湿度:	25~85% R.H.;
Operating Temperature Range 使用温度范围:	-10℃~+70℃;
Storage Temperature Range 保存温度范围:	-30℃~+80℃;
Normal Condition: 正常条件	
Ambient temperature 环境温度:	20±5℃
Relative humidity 相对湿度:	65%±5% R.H.;
Air pressure 气压:	86~101KPa;
Potentiometer 1&2: 电位器 1&2	
Total resistance 全阻值:	10K±20%
Resistance taper 阻抗特性形式:	Type "B"
Noise 接触杂音:	≤300mV
Voltage Divider error 分压误差:	41%~59%
Operation torque of shaft 轴操作扭力:	120±50gf.cm
Operation angle of shaft 轴操作角度:	55° Max.
Switch 开关	
Operation Force 操作力:	600±200gf;
Solder Ability 可焊性:	245±5℃, 3±0.5s;
Withstand Soldering Temperature 耐焊接热:	260±5℃, 3±0.5s;

4. Ratings/额定性能要求

Potentiometer 1&2: 电位器 1&2	
Max. operation voltage 最高使用电压:	50VAC / 5VDC;
Rated Power 额定功率	0.0125W
Insulation Resistance 绝缘电阻:	≥100MΩ / 250VDC;
Withstand Voltage 耐电压:	250VAC 1 Minute;
Mechanical Life 机械寿命:	1,800,000 Cycles (Without Load).
Switch 开关	
Contact Resistance 接触阻抗:	100mΩ Max;
Max. Rating 最大额定负荷:	12VDC / 50mA;
Insulation Resistance 绝缘电阻:	≥100MΩ / 100VDC;



Withstand Voltage 耐电压:
 Mechanical Life 机械寿命:

250VAC 1 Minute;
 1,000,000 Cycles (Without Load).

5. Profile Dimensions /外形尺寸

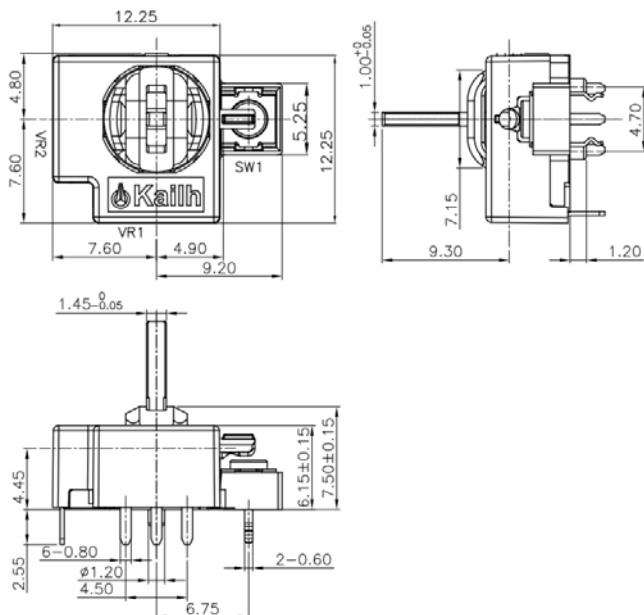

6. Electrical Performance (Potentiometer 1&2) 电气性能(电位器 1&2)

Item 项目	Description 项目描述	Test Condition 测试条件	Requirement 规格要求
6.1	Total resistance 全阻值	Between terminal 1 and terminal 3 1-3 端子间	10K±20%
6.2	Resistance taper 阻型特性型式	Percentage of the voltage of terminal 1-2 to the voltage of terminal 1-3 端子 1-2 电压与端子 1-3 电压的百分比值曲线	Type "B" "B"线型(直线型)
6.3	Rated voltage 额定电压	$E = \sqrt{PR}$ E:Rated voltage(V) P:Rated power(W) R:Nominal total resistance(Ω) The rated voltage is calculated by above formula. When the rated voltage exceeds the maximum operating voltage, the maximum operating voltage should be the rated voltage. E: 额定电压 P: 额定功率 R: 公称全阻值 额定电压按以上公式计算, 当额定电压超过最大工作电压时, 最大工作电压即为额定电压。	50VAC or 5VDC Max. operating voltage 50VAC或5VDC 最大工作电压



<p>6.4</p>	<p>Rated power 额定功率</p>	<p>The rated power should be changed according to the following chart when the ambient temperature changed. 额定功率与环境温度按以下曲线变化</p> <table border="1"> <caption>Power Rating Ratio vs Ambient Temperature</caption> <thead> <tr> <th>Ambient temperature (°C)</th> <th>Power rating ratio (%)</th> </tr> </thead> <tbody> <tr><td>0</td><td>100</td></tr> <tr><td>20</td><td>100</td></tr> <tr><td>40</td><td>100</td></tr> <tr><td>50</td><td>100</td></tr> <tr><td>60</td><td>66.7</td></tr> <tr><td>70</td><td>33.3</td></tr> </tbody> </table>	Ambient temperature (°C)	Power rating ratio (%)	0	100	20	100	40	100	50	100	60	66.7	70	33.3	<p>0.0125W</p>
Ambient temperature (°C)	Power rating ratio (%)																
0	100																
20	100																
40	100																
50	100																
60	66.7																
70	33.3																
<p>6.5</p>	<p>Contact Noise 接触杂音</p>	<p>Rated voltage shall be applied (D.C.) to the terminals between 1-3. And then noise shall be measured by circular operation with shaft operated 27.5° Speed of circular operation : 1 cycle/sec. 额定电压加在端子 1- 3 之间,轴倾斜 27.5° 圆周操作并测量杂音 轴圆周操作速度: 1 周/秒</p>	<p>≤300mVp-p</p>														
<p>6.6</p>	<p>Voltage Divider error 分压误差</p>	<p>Voltage divider error is defined the ratio of the voltage terminals 1-2 to terminals 1-3 after the drive arm rested. 5VDC shall be applied to the terminals between 1-3 and the voltage divider error shall be measured with the drive arm operation on the line X-X and Y-Y (terminal 1-2/terminal 1-3x100%) 分压误差值是摇杆自由复位后端子 1-2 与端子 1-3 电压比例 将 5VDC 电压加在端子 1-3 之间,分压误差值在摇杆转动 X-X 和 Y-Y 方向到底复位后测试 (端子 1-2/端子 1-3x100%)</p>	<p>41%-59%</p>														
<p>6.7</p>	<p>Insulation Resistance 绝缘电阻</p>	<p>250VDC shall be applied between individual terminals of potentiometer and frame for 1 minute. 电位器单独端子间及端子和外壳间施加 250VDC 电压 1 分钟</p>	<p>100MΩ Min 100 兆欧以上</p>														



6.8	Dielectric withstanding voltage 耐电压	250VAC (50~60HZ) shall be applied between adjacent terminals and between individual terminals of potentiometer and frame for 1 minute. Trip current 2mA. 以 250VAC(50~60HZ)施加于电位器单独端子间及端子和外壳间 1 分钟, 通过 2mA 电流	No evidence of breakdown 无瞬断、击穿等破坏.
-----	--	---	--

7. Switch characteristics 开关性能 (For with-switch type)

7.1	Operating Force 操作力	Applied side force perpendicular to the shaft's axial direction on the shaft until the shaft stops, measure the max force value. 将一个轴向力施加于摇杆上直到其不动为止, 量取施力期间最大值	600±200gf
7.2	Switch Travel 开关行程	The shaft shall be released and reset to vertical position. The static load twice the operating force (specified value) shall be applied to the shaft in vertical direction. the travel distance for the shaft to come to a stop shall be measured. 摇杆置于自然状态垂直方向, 2 倍静态负荷操作力作用在摇杆垂直方向, 测量摇杆自然状态到停止时移动距离	0.4 ^{+0.5} / _{-0.3} mm
7.3	Push strength 按压强度	Put the switch shaft upward; apply 3kgf of the static load over the vertical direction of the shaft for 60 seconds. 将开关摇杆置于垂直方向, 沿着操作方向施加 3KG 的负荷 60 秒	No mechanical and electrical malfunction. 电气、机械无异常
7.4	Circuit diagram 电路图		
7.5	Contact resistance 接触电阻	The shaft shall be released and reset to vertical position. The static load twice the operating force (specified value) shall be applied to the shaft in vertical direction. 摇杆置于自然状态垂直方向, 2 倍静态负荷操作力作用在摇杆垂直方向	<100mΩ.



7.6	Insulation resistance 绝缘电阻	Applied voltage 100VDC between adjacent terminals and between frame and individual terminals for 1 minute. 以 100VDC 施加于端子间及端子和外壳间	>100 MΩ
7.7	Dielectric withstanding voltage 耐电压	250VAC (50~60HZ) shall be applied between adjacent terminals and between frame and individual terminals for 1 minute. Trip current 2mA. 以 250VAC(50~60HZ)施加于端子间及端子和外壳间 1 分钟。通过 2mA 电流	Without breakdown. 无破坏现象

8. Mechanical Performance/机械性能

Item 项目	Description 项目描述	Test Condition 测试条件	Requirement 规格要求
8.1	Figure of shaft operation 摇杆动作形式	Circular operating 圆形式	Smooth turn 转动顺畅
8.2	Stopper strength of shaft 摇杆止动强度	Apply side force on the shaft perpendicular to the lever's axial direction. 垂直于摇杆的力作用于摇杆上	More than 5Kgf 3 seconds min. 大于 5Kgf 至少 3 秒钟
8.3	Pull Strength of shaft 摇杆拉拔强度	Apply specified pull force on the shaft upward. 作用于摇杆上, 沿摇杆方向向上	More than 5 Kgf 3 seconds min. 大于 5kg 至少 3 秒钟
8.4	Push strength of shaft 摇杆推强度	Apply specified push force on the shaft upward. 作用于摇杆上, 沿摇杆方向向下	More than 5 Kgf 3 seconds min. 大于 5kg 至少 3 秒钟
8.5	Operating torque of shaft 摇杆操作扭力	Test position: more than 10 degrees deflection of lever. 摇杆倾斜 10 度以上位置测定	120±50gf.cm
8.6	Accuracy of reset position of shaft 摇杆复位精度	Measure the angle between the shaft and the axial center line after the lever pushed to the direction of X-X(Y-Y) and resets. 摇杆推向 X-X(Y-Y)方向自由复位后测试摇杆与垂直中心线的角度	±5°
8.7	Operation angle of shaft 摇杆使用角度	The maximum angle of the shaft pushed to the direction of X-X and Y-Y and 45° 摇杆推向 X-X(Y-Y)和 45° 方向的最大角度	Refer to attached product drawing 见成品图

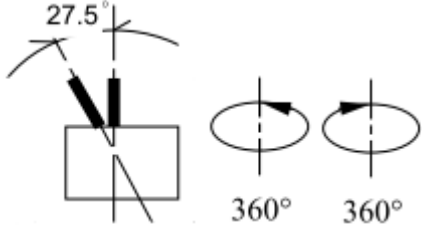

8.8	Operating life test 操作寿命	<p>1. Potentiometer 电位器</p> <p>a. Load: without load 负载: 不带负载</p> <p>b. Direction: shaft at 27.5° position 测试点位置: 轴向夹角 27.5°</p> <p>c. speed: 1 cycle/sec. 速度: 1 周/秒</p> <p>d. shaft motion angle: 360° 轴向转动角度: 360°</p> <p>f. number of cycles: 1,800,000 cycles 耐久次数: 180 万次</p> <div style="text-align: center;">  <p>27.5°</p> <p>360° 360°</p> </div> <p>2. Switch part 开关</p> <p>a. Load: without load 负载: 不带负载</p> <p>b. Direction: axial direction to the shaft which is released and reset to vertical position. 方向: 在摇杆垂直位置的轴向方向, 按压和复位</p> <p>c. Actuation force: 1000 gf 动作力: 1000gf</p> <p>d. Operation speed: 2 cycles/s 操作速度: 2 次/秒</p> <p>e. number of cycles: 1,000,000 cycles 耐久次数: 100 万次</p>	<p>Potentiometer 电位器</p> <p>a. Total resistance ≤ Initial value ±20%. 全阻变化在 ±20% 以内.</p> <p>b. Voltage Divider error: 41%~59%. 分压误差: 41%~59%</p> <p>c. Noise: ≤300mVp-p 杂音: ≤300mVp-p</p> <p>Switch part 开关</p> <p>a. Contact resistance: <200mΩ 接触电阻: <200mΩ</p> <p>b. Bounce: 10m sec max 触点抖动: <10 毫秒</p> <p>c. Shall meet: 以下满足: No. 7.1、7.2、7.5、7.6</p>
-----	-----------------------------	--	---

9. Environmental Performance/环境性能

Item 项目	Description 项目描述	Test Condition 测试条件	Requirement 规格要求
9.1	Free falling 自由跌落实验	Height: 75cm 高度: 75cm Number of falls: 3 times 跌落次数: 3 次	Without damage and shaft deformation, but deformations of terminals and molded parts are available. 摇杆未变形, 端子和其它塑胶零件除外



9.2	Cold test 耐寒性	<p>(1) Temperature : $-30 \pm 2^{\circ}\text{C}$ 温度: $-30 \pm 2^{\circ}\text{C}$</p> <p>(2) Duration of test: 96h 持续时间: 96 小时</p> <p>(3) Take off a drop water 去掉水珠</p> <p>(4) Standard conditions after test : 2h 试验后的放置条件: 2 小时</p>	<p>Variation of total resistance should be within 20% 全阻变化要在 20%以内, 机械方面能动作.</p> <p>Shall meet : 以下满足: No. 6.3、6.4、6.7、6.8 7.5、7.6</p>									
9.3	Heat test 耐热性	<p>(1) Temperature : $70 \pm 2^{\circ}\text{C}$ 温度: $70 \pm 2^{\circ}\text{C}$</p> <p>(2) Duration of test: 96h 持续时间: 96 小时</p> <p>(3) Take off a drop water 去掉水珠</p> <p>(4) Standard conditions after test : 2h 试验后的放置条件: 2 小时</p>	<p>The change of total resistance to the value of before test is: $+5\%$ -30% within. 全阻变化要在测试前 $+5\%$ -30% 以内</p> <p>Shall meet : 以下满足: No. 6.3、6.4、6.7、6.8 7.5、7.6</p>									
9.4	Damp heat 耐湿性	<p>Temperature: $+60 \pm 2^{\circ}\text{C}$ 温度: $60 \pm 2^{\circ}\text{C}$</p> <p>Humidity: 90~95%RH 湿度: 90~95%RH</p> <p>Duration of test: 96h 持续时间: 96 小时</p> <p>Standard conditions after test : 2h 试验后的放置条件: 2 小时</p>	<p>Insulation resistance: more than 10MΩ with 250V insulation resistance tester. The total resistance change should be within $\pm 20\%$. 用 250V 绝缘测试机测试, 绝缘阻抗 10MΩ 以上, 全阻值变化要在 $\pm 20\%$ 以内</p> <p>Shall meet : 以下满足: No. 6.3、6.4、6.7、6.8 7.5、7.6</p>									
9.5	Temperature cycle 温度循环	<p>(1) Test cycles: 5 cycles 试验周期: 5 个周期</p> <p>(2) Standard condition after test: 1h 试验后的放置条件: 2 小时</p> <table border="1"> <thead> <tr> <th></th> <th>Temperature 温度</th> <th>Duration of test 持续时间</th> </tr> </thead> <tbody> <tr> <td></td> <td>$-20 \pm 5^{\circ}\text{C}$</td> <td>0.5h</td> </tr> <tr> <td></td> <td>$60 \pm 5^{\circ}\text{C}$</td> <td>0.5h</td> </tr> </tbody> </table>		Temperature 温度	Duration of test 持续时间		$-20 \pm 5^{\circ}\text{C}$	0.5h		$60 \pm 5^{\circ}\text{C}$	0.5h	<p>The change of total resistance to the value of before test is: $\pm 20\%$ within. 全阻变化要在测试前 $\pm 20\%$ 以内</p> <p>Shall meet : 以下满足: No. 6.3、6.4、6.7、6.8 7.5、7.6</p>
	Temperature 温度	Duration of test 持续时间										
	$-20 \pm 5^{\circ}\text{C}$	0.5h										
	$60 \pm 5^{\circ}\text{C}$	0.5h										

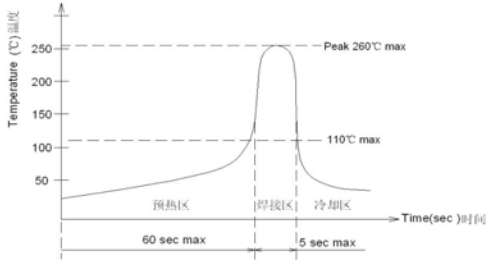

P/N: CJP127519D03-B	DOC. No.: KH-PS1905-24	Rev.: A	Page: 10/12
-------------------------------	----------------------------------	-------------------	-----------------------

<p>9.6</p>	<p>Soldering heat test 耐焊接热</p>	<p>Soldering area: T/2 of PWB thickness. (PWB: T=1.6mm) 焊接面积: 印刷基板的 1/2 厚度处 Soldering temperature: 260±5℃ Soldering time: 3±0.5s 焊接温度: 260±5℃ 焊接时间: 3±0.5 秒</p>	<p>Variation of total resistance shall be within ±5%, and terminals shall not work loose to injure electric contact after test. 全阻值变化±5%以内,测试后无端子松动,不会损坏电气接点</p>
<p>9.7</p>	<p>Solderability 可焊性</p>	<p>1. Hand soldering 手工焊接: Please practice according to below condition: (1) Soldering Temperature : 350±5℃ 焊接温度: 350±5℃ (2) Continual soldering time: 3±0.5s 连续焊接时间: 3±0.5 秒 (1) Capacity of soldering iron: ≤20w 电烙铁功率: 20 瓦以下 2. Automatic Reflow soldering 自动焊接: For the product of PIP, according to below condition:</p> 	<p>At least 95% of surface area of immersed portion shall be covered by solder. 浸焊面积大于 95%以上.</p>

10. Recommended PCB Layout 推荐的 PCB 安装焊盘规格

Top View & board T=1.6mm

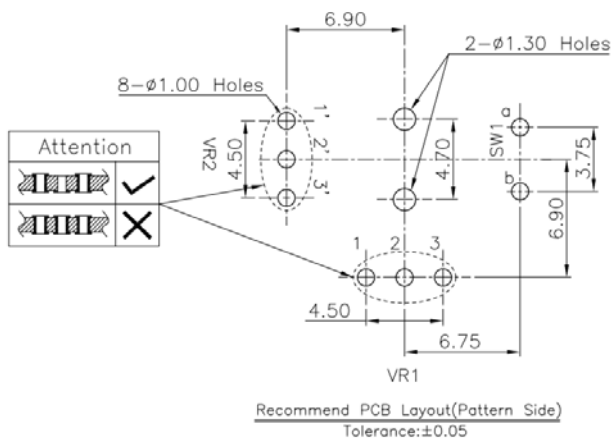



11. Packaging 包装

Packing Style 包装类型	Quantity 数量	Notes 说明
Forming Box 吸塑盒	100PCS.	
内纸箱 Inner Carton	1500PCS.	Forming Box: 15PCS
外纸箱 Outer Carton	3000PCS.	Inner Carton: 2PCS

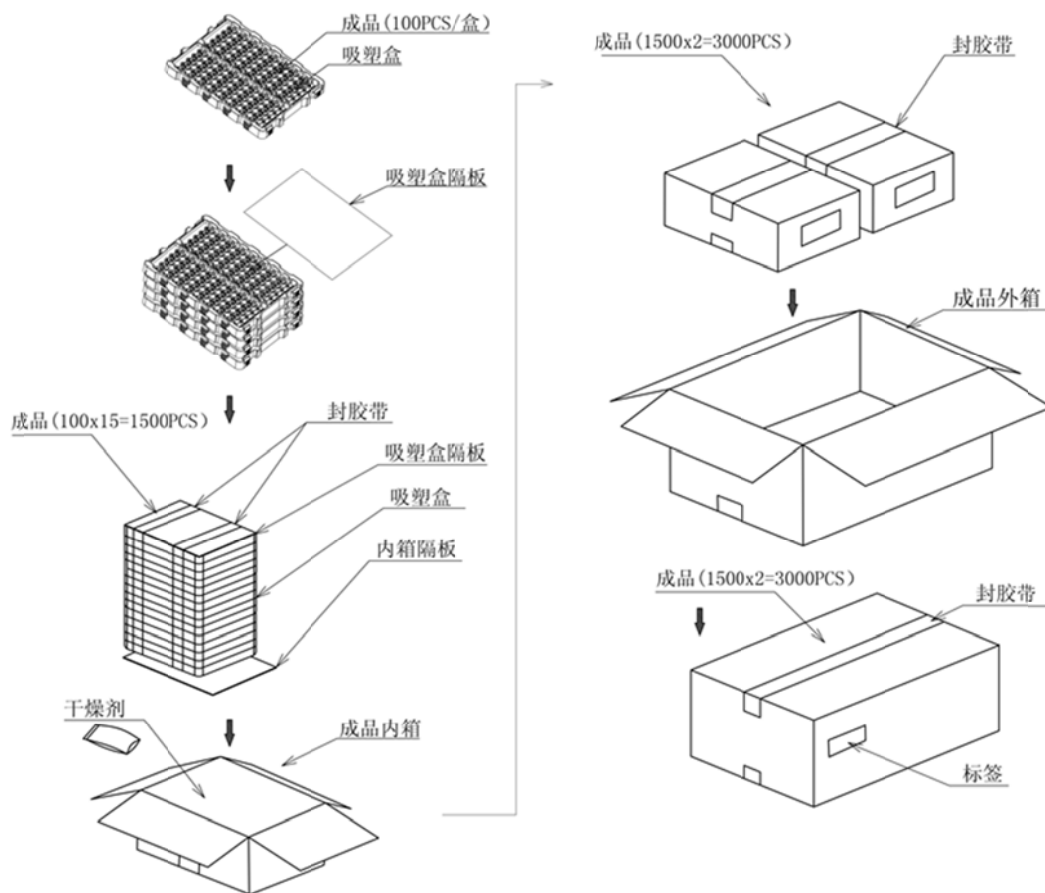

12. Precaution 注意事项

12.1 Immersion Soldering condition 浸焊条件

ITEM 项目	CONDITION 条件
Preheat temperature 预热温度	110°C Max (Ambient temperature of soldering surface of P.W.B) 110°C 以下(印刷基板焊锡面周围的温度)
Preheat time 预热时间	60s, Max 60 秒以内
Area of flux 助焊剂面积	1/2 Max of PWB Thickness 印刷基板厚度的 1/2 以内
Temperature of solder 焊锡温度	260 ± 5°C
Time of immersion 浸焊时间	Within 5s 5 秒以内



Number of soldering 焊接次数	2time Max (But should down heat of the first soldering) 2 次以内
Printed wiring board 印刷基板	Single side copper-clad laminates 单面铜箔

- (1) After switches were soldered, please be careful not to clean switches with solvent
开关浸焊后,注意不要用溶剂清洗.
- (2) Under the condition of using soldering iron, soldering temperature shall be 350°C max within 3 sec.
在使用烙铁的情况下,焊锡温度应在350°C以下,焊接时间3秒以内.

12.2 Notes 注意点

- (1) Please be cautious not to give excessive static load or shock to switches.
注意不要施加超负荷的压力或晃动开关.
- (2) Please be careful not to stack up P. W. B. after switches were soldered.
开关焊接以后,印刷基板注意不要叠放.
- (3) Preservation under high temperature and high humidity or corrosive gas should be avoided
Especially. When you need to preserve for a long period, do not open the carton.
保管时尤其应注意避开高湿高温和有腐蚀性气体的环境. 如需长时间保存,请不要打开包装箱.
- (4) Products meet the ROHS & REACH environmental management substances control standards
产品满足 **ROHS & REACH** 环境管理物质制标准.