

成品检验图面

枣红轴

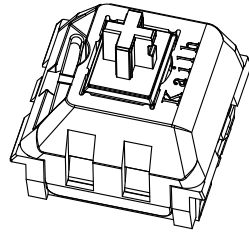
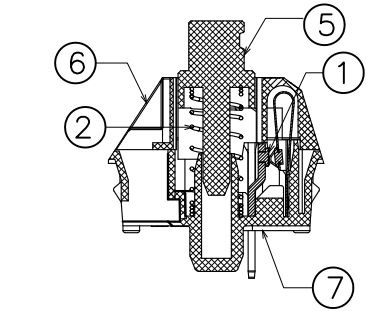
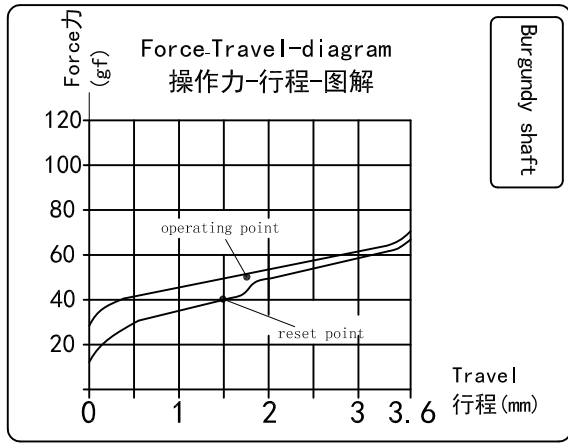
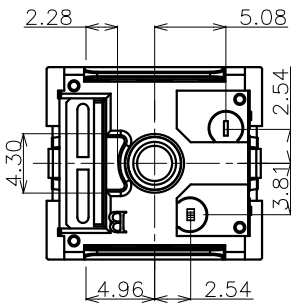
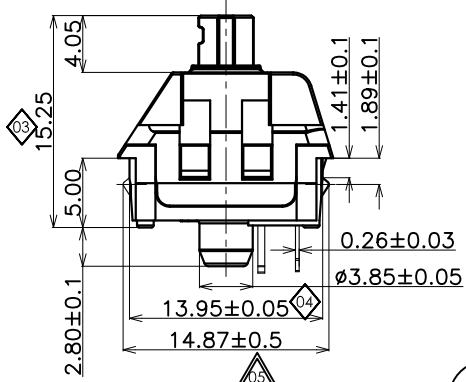
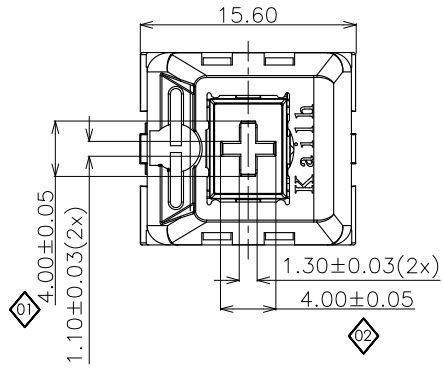

产品规格:

- 1. 额定值: 12V AC/DC max. 2V DC min.
10mA AC/DC max. 10µA DC min.
- 2. 接触阻抗: 100毫欧 最大
- 3. 绝缘阻抗: 100兆欧 最小 (DC500V)
- 4. 耐高压: 交流100伏 (50-60赫兹) 持续 1 分钟
- 5. 抖动时间: ≤5msec (3-4次/秒. 按压速度)
- 6. 操作力: 50±10gf
- 7. 导行程: 1.7±0.6mm (PT)
- 8. 全行程: 3.6±0.6mm
- 9. 操作寿命: 7000万次以上
- 10. 该产品需符合凯华环境有害物质管制标准

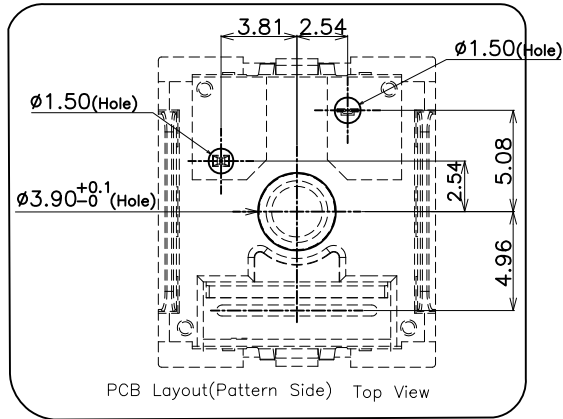
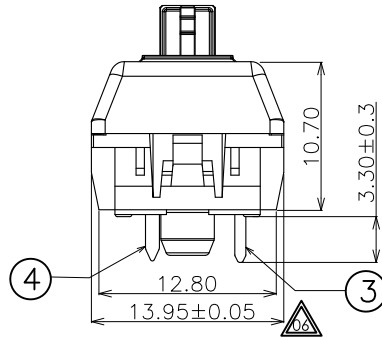

SWITCH FUNCTION

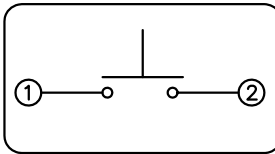

轴倾斜角度

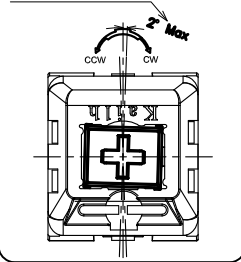

明细表:

| 序号 | 物料料号 | 零件名称 | 端子料号 | 用量 | 材料 | 镀层/颜色 | 备注 |
|----|----------------|--------|------|----|-----------------|-------|----|
| ⑦ | BSPG1518-02001 | 8#基座 | — | 1 | Nylon | 白色 | — |
| ⑥ | BSPG1511-04007 | 5#盖子 | — | 1 | PC | 透明 | — |
| ⑤ | BSPG1511-05040 | 枣红导芯 | — | 1 | poM | 枣红色 | — |
| ④ | BZPG1511-01026 | 9#动片 | — | 1 | Copper Alloy | — | — |
| ③ | BZPG1511-01055 | 8#静片 | — | 1 | Brass | 镍底镀锡 | — |
| ② | BWPG1511-03009 | A-2款弹簧 | — | 1 | Stainless Steel | — | — |
| ① | BWPG1511-09010 | 焊点金线 | — | 2 | — | — | — |

备注:

- ◇: 表示重点管控尺寸, 一般为功能尺寸, 首检时需量测。
- △: 表示次重点管控尺寸, 一般为装配尺寸, 首检时需量测。
- 1) 重点及次重点管控尺寸中的序号不可重复, 需依次往后增加。若其中有某个尺寸在变更或其它状况下, 尺寸消失或不要求管控时, 原序号不可再用。有其它尺寸需要增加管控时, 序号往后增加。
- 2) 版次定义: 新开发而未转量产之产品图面版次为A1, A2, A3... 已转量产之产品图面版次为A, B, C...

| | | | | | | |
|--------|----------------|---|------------------|--------|----------------|-----------|
| 承认 | 日期 | 东莞市凯华电子有限公司 DONGGUAN CITY KAIHUA ELECTRONICS CO.,LTD | | | | |
| 设计 | 王泳翔 2017.06.16 | | | | | |
| 审核 | | 名称 | PG1511按键开关 (枣红轴) | | | |
| 核准 | | 料号 | CPG151101D221 | | | |
| 未注尺寸公差 | 30<L | ±0.30 | 角度 | 单位: mm | 比例: 1:1 | 视角 |
| | 10<L | ±0.20 | | | | |
| | 5<L | ±0.15 | ±2° | 图号: | KHA-PG1511-181 | 页次 1 OF 1 |
| | L | ±0.10 | | | | |

| | | | | | | |
|-------------|----|------------|--------------|-----|----|----|
| ECN-1905-14 | B | 2019.12.19 | 静片由镀镍变更为镍底镀锡 | 胡前程 | | |
| | A | | New | | | |
| 工程变更单号 | 版次 | 日期 | 说明 | 修改 | 审核 | 核准 |



凱華電子
KAIHUA EEELETRONICS

Document Number:

KH-PS1707-27

产品规格书

Product Specification

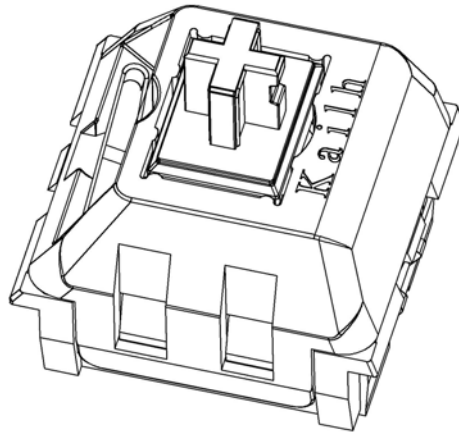

| P/N: CPG151101D221 | | | Title : PG1511 Keyboard Switch | | |
|---------------------------|-----|-----------------------------------|---------------------------------------|------------------|-------------------|
| Rev. | ECN | Release and Revision Description: | Prepared By /Date: | Checked By/Date: | Approved By/Date: |
| A | — — | New releasing 初版发行 | 胡前程/2019.12.26 | 戴长青/2019.12.26 | 戴长青/2019.12.26 |
| | | | | | |
| | | | | | |
| | | | | | |
| | | | | | |



| | | | |
|-----------------------|---------------------------|------------|---------------|
| P/N: CPG151101D221 | DOC. No.: KH-PS1707-27 | Rev.: A | Page: 2/12 |
|-----------------------|---------------------------|------------|---------------|

Content

目录

| | |
|--|-------|
| 1. Scope/范围: | 3 |
| 2. Product Application/产品应用: | 3 |
| 3. Technology Parameters/技术参数 | 3 |
| 4. Ratings/额定性能要求 | 3 |
| 5. Profile Dimensions /外形尺寸 | 3 |
| 6. Electrical Performance/电气性能 | 4 |
| 7. Mechanical Performance/机械性能 | 5-6 |
| 8. Environmental Performance/环境性能 | 7-9 |
| 9. Recommended PCB Layout/推荐的 PCB 安装焊盘规格 | 10 |
| 10. Loading Parameter Specification/荷重参数规格 | 11 |
| 11. Packaging/包装 | 11 |
| 12. Precaution/注意事项 | 11-12 |



| | | | |
|------------------------------|----------------------------------|-------------------|----------------------|
| P/N: CPG151101D221 | DOC. No.: KH-PS1707-27 | Rev.: A | Page: 3/12 |
|------------------------------|----------------------------------|-------------------|----------------------|

1. Scope/范围:

This Product Specification covers the requirement of Mechanical Keyboard switch on product performance, test methods and quality assurance provisions.
本规格书内容涵盖机械键盘开关产品的要求，包括性能指标、测试方法及质量保证方面等。

2. Product Application/产品应用:

Mainly applied on computer keyboards, cash registers, industrial equipment and Man-Machine interface.
主要适用于电脑键盘，收银机、工业设备和人机界面。

3. Technology Parameters/技术参数

| | |
|---|------------------------|
| Ambient Humidity 工作湿度: | 45~85% R.H.; |
| Operating Temperature Range 使用温度范围: | -10°C~+70°C; |
| Storage Temperature Range 保存温度范围: | -20°C~+70°C; |
| Suggested storage period 贮存期限: | about 6 months 最多 6 个月 |
| Require the tin part on the switch terminals should keep good after storage guarantee date 要求贮存期后开关端子部分上锡仍然良好。 | |
| Normal Condition: | |
| Ambient temperature 环境温度: | 20±2°C |
| Relative humidity 相对湿度: | 65%±5% R.H.; |
| Air pressure 气压: | 86~101KPa; |

4. Ratings/额定性能要求

| | |
|-----------------------------|---|
| Rating 额定负荷: | 12V AC/DC max.2V DC min. 10mA AC/DC max.10 μ A DC min; |
| Insulation Resistance 绝缘电阻: | ≥100MΩ/DC 500V; |
| Withstand Voltage 耐电压: | 100 AC 1 Minute; |
| Mechanical Life 机械寿命: | 70,000,000 Cycles. |

5. Profile Dimensions /外形尺寸

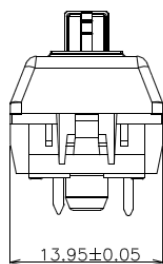
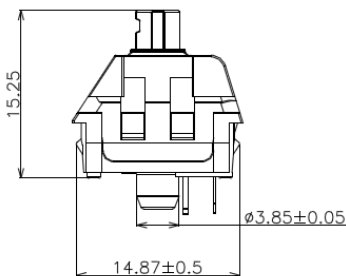
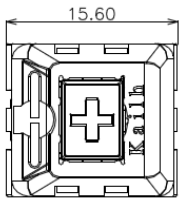

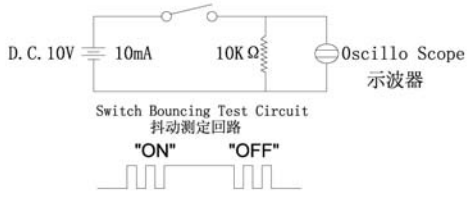

6. Electrical Performance/电气性能

| Item 项目 | Description 项目描述 | Test Condition 测试条件 | Requirement 规格要求 |
|------------|--|---|--|
| 6.1 | Contact Resistance 接触电阻 | <p>Static load: (Operation force)x2, which is applied on the center of Switch stem. 静态负载：动作力的 2 倍，施加在手柄中心.</p> <p>Measurement tool: Contact resistance Meter. 测量工具：微电流接触电阻计(1KHz, 20mV,5~50mA)</p> <p>在低电流 (≤100mA) 条件下测试. Measured at low current (100mA or less).</p> | <p>100mΩ Max 100mΩ 以下</p> |
| 6.2 | Insulation Resistance 绝缘电阻 | <p>Apply a Voltage of DC 500 V for 1 minute, according to the below method. (1) Between terminals. (2) Between terminal and Body.</p> <p>输入 500V DC 电压 1 分钟，按如下接触方法测试： (1) 端子与端子之间。 (2) 端子与外壳之间。</p> | <p>100MΩ Min 100 兆欧以上</p> |
| 6.3 | Dielectric withstanding voltage 耐电压 | <p>Apply a Voltage of AC100 V (50~60Hz) for 1 minute, according to the below method. (1) Between terminals. (2) Between terminal and Body.</p> <p>输入 100V AC 电压 1 分钟，按如下接触方法测试： (1) 端子与端子之间。 (2) 端子与外壳之间。</p> | <p>No evidence of breakdown 无瞬断、击穿等破坏。</p> |
| 6.4 | Bouncing 触点抖动 | <p>Operation speed: 3~4 times/s 操作速度：每秒 3~4 次</p> <p>Oscillo scope 示波器</p> <p>Switch Bouncing Test Circuit 抖动测定回路。</p>  | <p>Before Life cycle: On:5ms MAX,5 毫秒以下 Off: 5ms MAX,5 毫秒以下</p> <p>After Life cycle: On:10ms MAX,10 毫秒以下 Off: 10ms MAX,10 毫秒以下</p> |

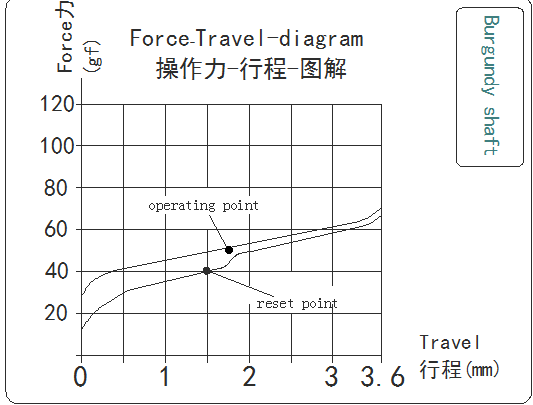
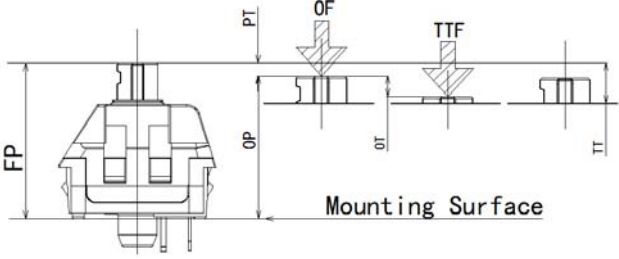

7. Mechanical Performance/机械性能

| Item 项目 | Description 项目描述 | Test Condition 测试条件 | Requirement 规格要求 |
|------------|---------------------------|--|------------------------|
| 7.1 | Load Curve 荷重曲线 | <p>Place the vertical direction of switch operation and gradually increase the load applied to the center of the stem until it stop. 开关的动作方向为垂直放置，向手柄中心逐渐施加负荷直到停止。</p>  | See page 11 见第 11 页 |
| 7.2 | Loading parameter 荷重参数 | <p>Place the vertical direction of switch operation and gradually increase the load applied to the center of the stem until it stop. 开关的动作方向为垂直放置，向手柄中心逐渐施加负荷直到停止。</p>  | See page 11 见第 11 页 |

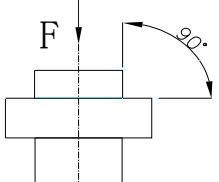
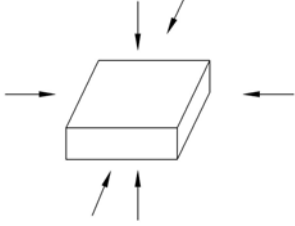

| | | | |
|-----|-------------------------------------|---|---|
| 7.3 | Static Strength 静止强度 | <p>A static load of 3kgf shall be applied in the direction of button operation for a period of 60 seconds. 在手柄动作方向施加 3kgf 的静负荷 60 秒, 然后测试参数.</p>  | <p>No damage (Electrical) And mechanical) 电气和机械性能正常.</p> |
| 7.4 | Stem Pull Strength 手柄拉拔强度 | <p>Break by a pull force applied opposite to the direction of stem operation. 在推柄动作方向反向垂直施加拉力, 使其破坏的程度.</p> | <p>5kgf Min</p> |
| 7.5 | Shock 机械冲击 | <p>Measured by according to the below condition: (1) Acceleration: 80g 加速度 (2) Cycles of test: 3 cycles each in 6 directions, for a total of 18 cycles. 试验次数: 每个方向 3 次, 6 个方向共 18 次.</p>  | <p>Shall meet No.6, 7.1, 7.2. 满足 6, 7.1, 7.2 要求.</p> |
| 7.6 | Life Test 寿命测试 | <ol style="list-style-type: none"> 1) D.C. 12V 10mA resistance load D.C 12V 10mA 电阻负荷 2) Operation speed : 5-6 times / s 动作速度: 5-6 次/秒 3) Push force : 150gf 按力: 150gf 5) Push travel : 3.6mm 按压行程: 3.6mm 6) Operation number: 70,000,000cycles 动作次数: 70, 000, 000 次 | <p>Contact resistance: 1000 mΩ Max 接触电阻: 1000 毫欧以下 Bouncing: 10ms Max 触点抖动: 10 毫秒以下 Operation force: Variation rate within ± 30% 操作力的变化范围在初始值的±30%以内.</p> |



8. Environmental Performance/环境性能

| Item 项目 | Description 项目描述 | Test Condition 测试条件 | Requirement 规格要求 | | | | | | | | | | | | |
|-----------------|--------------------------------|---|--|-------------------|--------------------------|-----------------|-------|----|--------|----|-------|----|-------|----|--|
| 8.1 | Cold test 耐寒性 | (1) Temperature : - 20±2℃ 温度: - 20±2℃ (2) Duration of test: 48h 持续时间: 48 小时 (3) Take off a drop water 去掉水珠 (4) Standard conditions after test : 1h 试验后的放置条件: 1 小时 | Contact resistance: 200mΩ Max Shall meet : No. 6.2 to 6.4 No. 7.1 to 7.2 接触电阻 200mΩ 以下 满足: No. 6.2 to 6.4 No. 7.1 to 7.2 | | | | | | | | | | | | |
| 8.2 | Heat test 耐热性 | (1) Temperature : 70±2℃ 温度: 70±2℃ (2) Duration of test: 48h 持续时间: 48 小时 (3) Take off a drop water 去掉水珠 (4) Standard conditions after test : 1h 试验后的放置条件: 1 小时 | Contact resistance: 200mΩ Max Shall meet : No. 6.2 to 6.4 No. 7.1 to 7.2 接触电阻 200mΩ 以下 满足: No. 6.2 to 6.4 No. 7.1 to 7.2 | | | | | | | | | | | | |
| 8.3 | Temperature cycle 温度循环 | (1) Test cycles: 5 cycles 试验周期: 5 个周期 (2) Standard condition after test:1h 试验后的放置条件: 1 小时 <table border="1" data-bbox="432 1368 1037 1559"> <thead> <tr> <th></th> <th>Temperature 温度</th> <th>Duration of test 持续时间</th> </tr> </thead> <tbody> <tr> <td rowspan="4">1 cycle 一次循环</td> <td>20±5℃</td> <td>1h</td> </tr> <tr> <td>-20±2℃</td> <td>1h</td> </tr> <tr> <td>20±5℃</td> <td>1h</td> </tr> <tr> <td>70±5℃</td> <td>1h</td> </tr> </tbody> </table> | | Temperature 温度 | Duration of test 持续时间 | 1 cycle 一次循环 | 20±5℃ | 1h | -20±2℃ | 1h | 20±5℃ | 1h | 70±5℃ | 1h | Contact resistance: 200mΩ Max Shall meet : No. 6.2 to 6.4 No. 7.1 to 7.2 接触电阻 200mΩ 以下 满足: No. 6.2 to 6.4 No. 7.1 to 7.2 |
| | Temperature 温度 | Duration of test 持续时间 | | | | | | | | | | | | | |
| 1 cycle 一次循环 | 20±5℃ | 1h | | | | | | | | | | | | | |
| | -20±2℃ | 1h | | | | | | | | | | | | | |
| | 20±5℃ | 1h | | | | | | | | | | | | | |
| | 70±5℃ | 1h | | | | | | | | | | | | | |
| 8.4 | Soldering heat test 耐焊接热 | Soldering area: T/2 of PWB thickness. (PWB: T=1.6mm) 焊接面积: 印刷基板的 1/2 厚度处 Soldering temperature: 260±5℃ Soldering time: 5±0.5s 焊接温度: 260±5℃ 焊接时间: 5±0.5 秒 | Appearance: No abnormality. 外观无异常 | | | | | | | | | | | | |

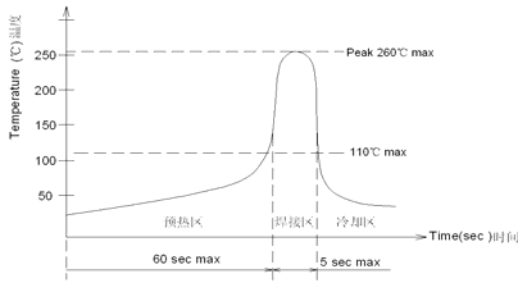

| | | | | |
|-----|-----------------------|--|---|--|
| 8.5 | Solder ability 可焊性 | <p>1. Hand soldering 手工焊接: Please practice according to below condition: (1) Soldering Temperature : $350 \pm 5^\circ\text{C}$ 焊接温度: $350 \pm 5^\circ\text{C}$ (2) Continual soldering time: $3 \pm 0.5\text{s}$ 连续焊接时间: 3 ± 0.5 秒 (1) Capacity of soldering iron: $\leq 20\text{w}$ 电烙铁功率: 20 瓦以下</p> <p>2. Automatic PIP soldering 自动插板焊接: For the product of T/H according to below condition:</p> <p style="text-align: center;">波峰焊温度曲线图(单波峰)</p>  | <p>At least 95% of surface area of immersed portion shall be covered by solder. 侵焊面积大于 95%以上.</p> | |
| 8.6 | Humidity test 耐湿性 | <p>(1) Temperature : $60 \pm 2^\circ\text{C}$ 温度: $60 \pm 2^\circ\text{C}$ (2) relative humidity: 90~95% R.H. 相对湿度:90~95% R.H. (3) Duration of test: 48h 持续时间: 48 小时 (4) Take off a drop water 去掉水珠 (5) Standard conditions after test: 1h 试验后的放置条件: 1 小时</p> | <p>Contact resistance: $200\text{m}\Omega$ Max Shall meet : No. 6.2 to 6.4 No. 7.1 to 7.2 接触电阻 $200\text{m}\Omega$ 以下 满足: No. 6.2 to 6.4 No. 7.1 to 7.2</p> | |
| 8.7 | Salt Spray 盐雾测试 | <p>Apply the following environment to test: 根据下列条件进行测试: (1) Temperature : $35 \pm 5^\circ\text{C}$ 温度: $35 \pm 5^\circ\text{C}$; (2) Salt water density: $5 \pm 1\%$ 盐水浓度: $5 \pm 1\%$; (3) Duration: 12hours 持续时间: 12 小时; (4) After test, the salt deposit shall be removed by running water. 实验后将盐沉积物用水冲掉</p> | <p>Appearance: No corrosion spot, no crack, no base plate naked. 外观: 无腐蚀点, 无裂纹, 无裸露基材.</p> <p>Contact Resistance: $200\text{m}\Omega$ Max 接触电阻: 200 毫欧以下</p> | |



8.8

Withstand
K₂S
硫化测试

Apply the following environment to test:
根据下列条件进行测试

- (1) Temperature: 35 ± 5 °C 温度: 35 ± 5 °C
- (2) K₂S Density: 2%;
硫化钾浓度: 2%
- (3) Duration: 2 minute.
持续时间: 2 分钟

Appearance:
No corrosion spot, no crack, no base plate naked.
外观: 无腐蚀点, 无裂纹, 无裸露基材.

Contact Resistance:
1000 m Ω Max
接触电阻: 1000 毫欧以下



9. Recommended PCB Layout 推荐的 PCB 安装焊盘规格

Mounting Options 安装选项

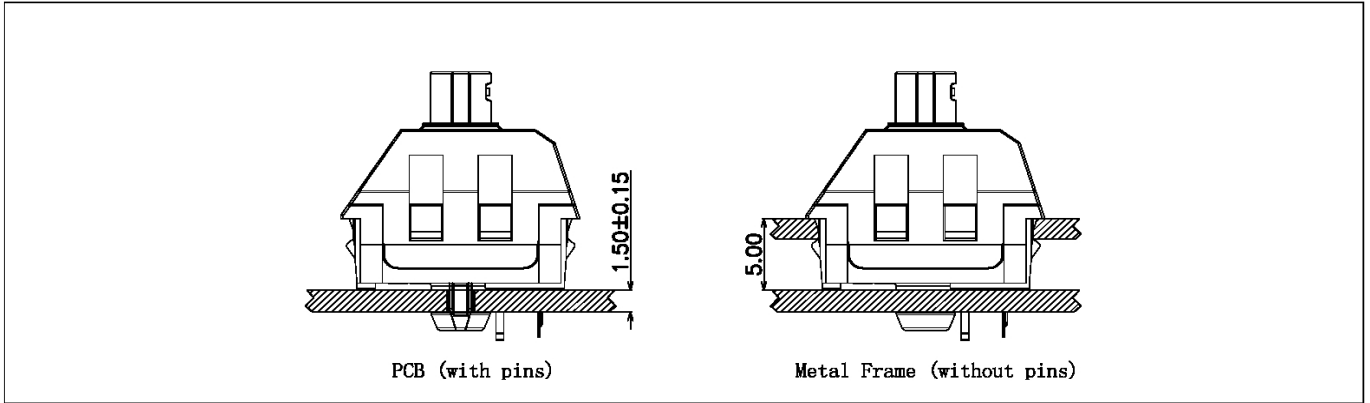

Circuit Board Layouts 电路板布局

Grid line spacing = 1.27mm 网格线间距= 1.27毫米

Keyswitch without fixation pins
按键开关不带定位柱

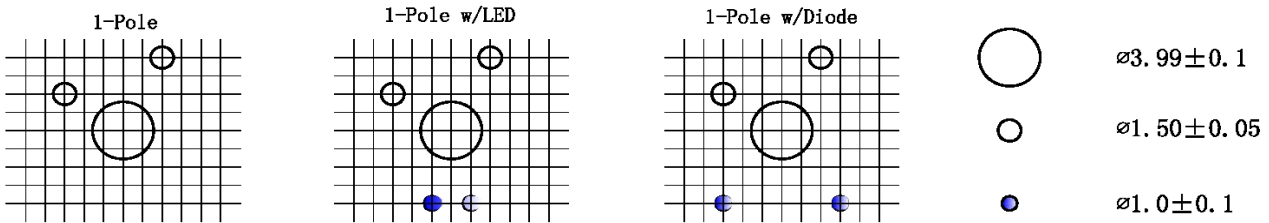

Keyswitch with fixation pins
按键开关带定位柱

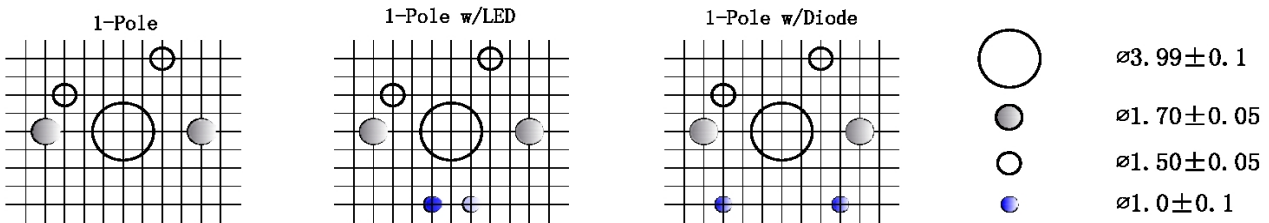

Metal Frame Cutout Dimensions

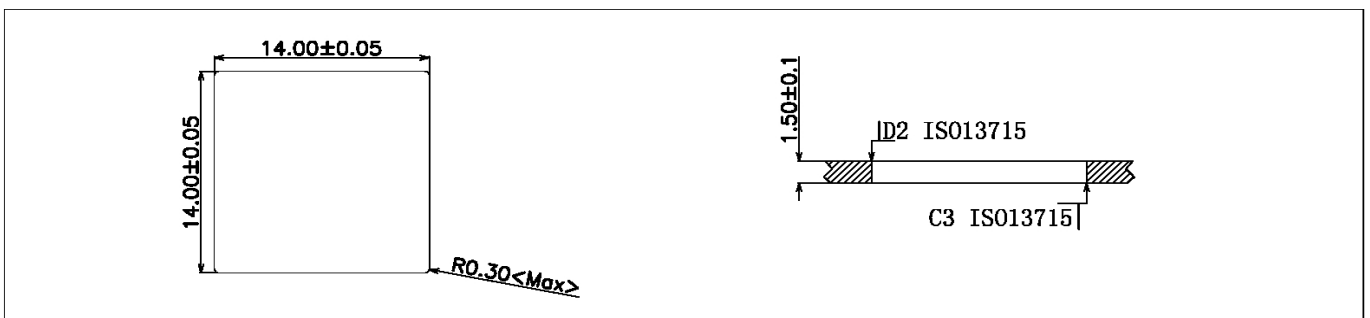



10. Loading Parameter (FP/OP/PT/ OF /OT) Specification 荷重参数规格：

| Parameter | Unit | Specification | Remark |
|-----------|------|---------------|--------|
| FP (自由行程) | mm | 15.25±0.2 | |
| OP (动作位置) | mm | 13.55±0.7 | |
| PT (导通行程) | mm | 1.7±0.60 | |
| OF (操作力) | gf | 50±10 | |
| OT (过行程) | mm | 0.7 | Min |
| TT(全行程) | mm | 3.6±0.6 | |

11. Packaging 包装

(1)Packaging type: Tray, 1000Pcs/Tray, 4000Pcs/Carton.

包装方式: Tray 盘,1000Pcs/盘, 4000Pcs/箱.

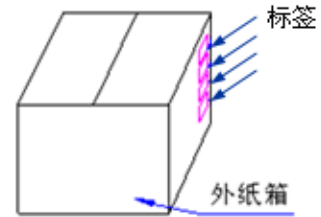
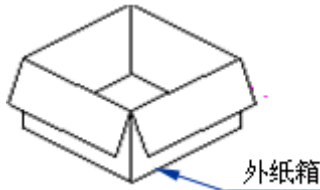

12.Precaution 注意事项

12.1 Immersion Soldering condition 浸焊条件

| ITEM 项目 | CONDITION 条件 |
|-------------------------------|---|
| Preheat temperature 预热温度 | 110°C Max (Ambient temperature of soldering surface of P.W.B) 110°C 以下(印刷基板焊锡面周围的温度) |
| Preheat time 预热时间 | 60s, Max 60 秒以内 |
| Area of flux 助焊剂面积 | 1/2 Max of PWB Thickness 印刷基板厚度的 1/2 以内 |
| Temperature of solder 焊锡温度 | 260±5°C 260±5°C |
| Time of immersion 浸焊时间 | Within 5s 5 秒以内 |
| Number of soldering 焊接次数 | 2time Max (But should down heat of the first soldering) 2 次以内 |
| Printed wiring board 印刷基板 | Single side copper-clad laminates 单面铜箔 |

(1) After switches were soldered, please be careful not to clean switches with solvent

开关浸焊后,注意不要用溶剂清洗.

(2) Under the condition of using soldering iron, soldering temperature shall be 350°C max within 3 sec.

在使用烙铁的情况下,焊锡温度应在350°C以下,焊接时间3秒以内.



| | | | |
|-----------------------|---------------------------|------------|----------------|
| P/N: CPG151101D221 | DOC. No.: KH-PS1707-27 | Rev.: A | Page: 12/12 |
|-----------------------|---------------------------|------------|----------------|

12.2 Notes 注意点

- (1) Please be cautious not to give excessive static load or shock to switches.
注意不要施加超负荷的压力或晃动开关.
- (2) Please be careful not to stack up P. W. B. after switches were soldered.
开关焊接以后,印刷基板注意不要叠放.
- (3) Preservation under high temperature and high humidity or corrosive gas should be avoided
Especially. When you need to preserve for a long period, do not open the carton.
保管时尤其应注意避开高湿高温和有腐蚀性气体的环境.如需长时间保存,请不要打开包装箱.
- (4) Products meet the ROHS & REACH environmental management substances control standards
产品满足 [ROHS & REACH](#) 环境管理物质管制标准