

成品检验图面

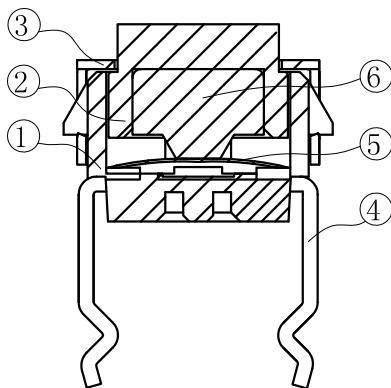

SECTION A-A

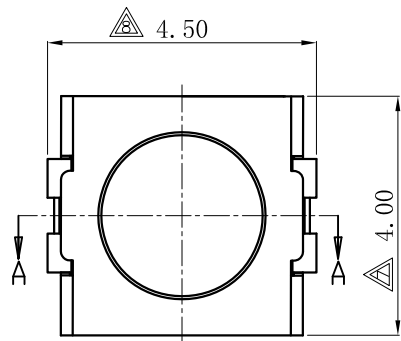
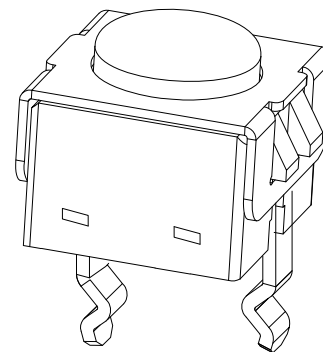

技术要求:

- 1. 额定值:DC 5V 30mA
- 2. 接触阻抗: 100mΩ (Max)
- 3. 绝缘阻抗: 50MΩ (Min) DC250V
- 4. 耐高压:AC500V(50-60Hz)持续 1 分钟
- 5. 操作力:90±20gf
- 6. 行程:0.35±0.15mm
- 7. 寿命测试:1,000,000次
- 8. 手感率(CR):50%±20 (OF-CF)/OF*100%
- 8. 该产品需符合<<凯华环境有害物质管制标准>>

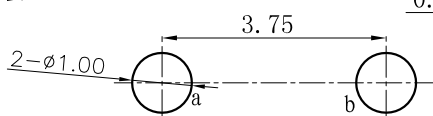
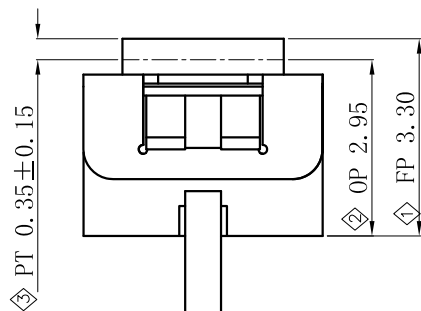
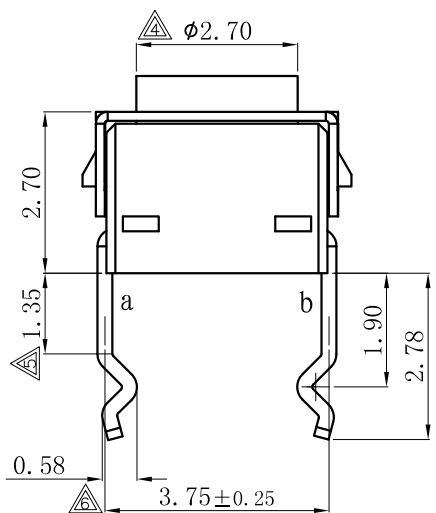

PCB Layout

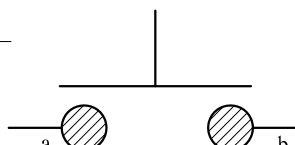

Circuit Diagram

备注:

◇: 表示重点管控尺寸, 一般为功能尺寸, 首检及巡检时需量测。
 △: 表示次重点管控尺寸, 一般为装配尺寸, 首检时需量测。
 1) 重点及次重点管控尺寸中的序号不可重复, 需依次往后增加。若其中有某个尺寸在变更或其它状况下, 尺寸消失或不要求管控时, 原序号不可再用。有其它尺寸需要增加管控时, 序号往后增加。
 2) 版次定义: 新开发而未转量产之产品图面版次为A1, A2, A3...
 已转量产之产品图面版次为A, B, C...

序号	零件	物料料号	用量	材料	镀层/颜色	备注
⑥	橡胶垫		1	硅胶 (70°)	绿色(Green)	
⑤	φ3.0弹片		1	SUS301 EH(80g)	本色(Natural)	
④	端子		1	H65Y t=0.25	镀银(Ag)	
③	外壳		1	SUS304 1/2H	本色(Natural)	
②	导芯		1	PA66 G30	黑色(Black)	
①	基座		1	PA66 G30	黑色(Black)	

承认	日期	 东莞市凯华电子有限公司 KAHUA ELECTRONICS CO.,LTD	
设计	胡前程 2017/06/28		
审核		名称	TA4033 轻触开关
核准		料号	CTA403301D02
未注尺寸公差		30<L ≤30 ±0.30 10<L ≤30 ±0.20 5<L ≤10 ±0.15 L≤5 ±0.10	角度 单位: mm 比例: 8:1 视角
工程变更单号		图号	KHA-TA4033-002
版次		页次 1 OF 1	

ECN-1707-07	B	2017.07.14	产品寿命改善更换硅胶硬度	胡前程		
	A		NEW			
工程变更单号	版次	日期	说明	修改	审核	核准



凱華電子
KAIHUA EEELETRONICS

Document Number:

KH-PS1609-09

产品规格书

Product Specification

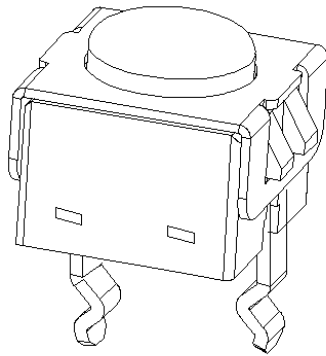

P/N: _____

CTA403301D02

Title :

Tact Switch

Rev.	ECN	Release and Revision Description:	PreparedBy/Date:	Checked By/Date:	Approved By/Date:
A	-----	New releasing 初版发行			
B	ECN-1707-07	产品寿命改善更换硅胶硬度	胡前程 2017.07.20	吕攀豪 2017.07.20	David 2017.07.20



P/N: CTA403301D02	DOC. No.: KH-PS1609-09	Rev.: A	Page: 2/10
----------------------	---------------------------	------------	---------------

Content

目录

1. Scope/范围:.....	3
2. Product Application/产品应用 :	3
3. Technology Parameters/技术参数	3
4. Ratings/额定性能要求.....	3
5. Profile Dimensions /外形尺寸	3
6. Electrical Performance/电气性能	4
7. Mechanical Performance/机械性能.....	5
8. Environmental Performance/环境性能.....	7
9. Recommended PCB Layout/推荐的 PCB 安装焊盘规格	9
10. Packaging 包装:	9
11. Precaution/注意事项	10



P/N: CTA403301D02	DOC. No.: KH-PS1609-09	Rev.: A	Page: 3/10
-----------------------------	----------------------------------	-------------------	----------------------

1. Scope/范围:

This Product Specification covers the requirement of tact switch on product performance, test methods and quality assurance provisions.
本规格书内容涵盖轻触开关产品的要求，包括性能指标、测试方法及质量保证方面等。

2. Product Application/产品应用:

The Switch is applied in all types of Computer. Please let us know before using any of the products in the application not described above.
该开关产品适用于所有类型的家用电器，如果用于本文中未提及的领域请在使用前告知。

3. Technology Parameters/技术参数

Ambient Humidity 工作湿度:	45~85% R.H.;
Operating Temperature Range 使用温度范围:	-10℃~+70℃;
Storage Temperature Range 保存温度范围:	-20℃~+70℃;
Normal Condition:	
Ambient temperature 环境温度:	20±5℃
Relative humidity 相对湿度:	65%±5% R.H.;
Air pressure 气压:	86~101KPa;
Contact Resistance 接触阻抗:	100 mΩ Max;
Operation Force 操作力:	90±20gf;
Solder Ability 可焊性:	245±5℃,3±0.5s;
Withstand Soldering Temperature 耐焊接热:	260±5℃,3±0.5s;

4. Ratings/额定性能要求

Rating 额定负荷:	DC5V / 30mA;
Insulation Resistance 绝缘电阻:	≥50MΩ/DC 250V;
Withstand Voltage 耐电压:	500V AC 1 Minute;
Mechanical Life 机械寿命:	1,000,000 Cycles (No lead).

5. Profile Dimensions /外形尺寸

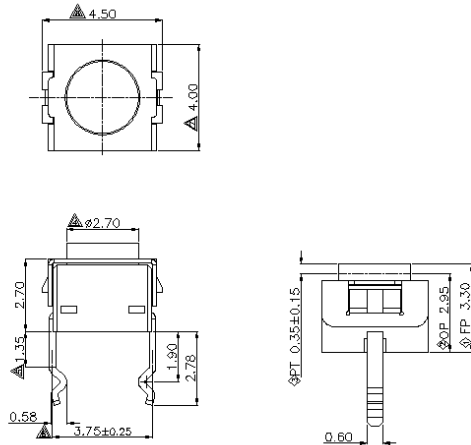



P/N: CTA403301D02	DOC. No.: KH-PS1609-09	Rev.: A	Page: 4/10
-----------------------------	----------------------------------	-------------------	----------------------

6. Electrical Performance/电气性能

Item 项目	Description 项目描述	Test Condition 测试条件	Requirement 规格要求
6.1	Contact Resistance 接触电阻	<p>Static load: (Operation force)x2, which is applied on the center of Switch stem. 静态负载: 动作力的 2 倍, 施加在手柄中心.</p> <p>Measurement tool: Contact resistance Meter. 测量工具: 微电流接触电阻计(1KHz, 20mV,5~50mA)</p> <p>在低电流 (≤100mA) 条件下测试. Measured at low current (100mA or less).</p>	<p>100mΩ Max 100mΩ 以下</p>
6.2	Insulation Resistance 绝缘电阻	<p>Apply a Voltage of DC 250 V for 1 minute, according to the below method. (1) Between terminals. (2) Between terminal and Body.</p> <p>输入 250V DC 电压 1 分钟, 按如下接触方法测试: (1) 端子与端子之间. (2) 端子与外壳之间.</p>	<p>50MΩ Min 50 兆欧以上</p>
6.3	Dielectric withstanding voltage 耐电压	<p>Apply a Voltage of AC 500 V (50~60Hz) for 1 minute, according to the below method. (1) Between terminals. (2) Between terminal and Body.</p> <p>输入 500V AC 电压 1 分钟, 按如下接触方法测试: (1) 端子与端子之间. (2) 端子与外壳之间.</p>	<p>No evidence of breakdown 无瞬断、击穿等破坏.</p>
6.4	Bouncing 触点抖动	<p>Operation speed: 1~2 times/s 操作速度: 每秒 1~2 次</p> <p>Slightly push the center of stem by 1~2 times/s, to test the bounce at "ON" and "OFF" 以每秒 1~2 次的速度, 轻轻在手柄中心加力, 在"导通"与"瞬断"间测试.</p> <p>Oscillo scope 示波器 Switch Bouncing Test Circuit 抖动测定回路.</p>	<p>Before Life cycle: On:5ms MAX,5 毫秒以下 Off: 5ms MAX,5 毫秒以下</p> <p>After Life cycle: On:10ms MAX,10 毫秒以下 Off: 10ms MAX,10 毫秒以下</p>



触点抖动用图：

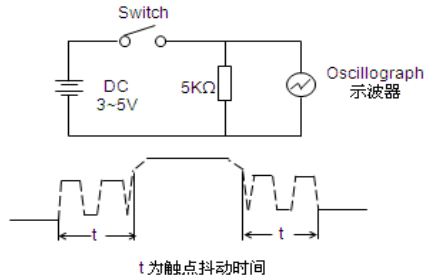

7. Mechanical Performance/机械性能

Item 项目	Description 项目描述	Test Condition 测试条件	Requirement 规格要求
7.1	Operation force 操作力	<p>Operate the keystone of the switch and then increase press strength gradually, Measured maximum operation force while the travel of the switch is full.</p> <p>逐渐施力操作开关按键，测量开关到达全部工作行程时所需的最大操作力度。</p>	90±20gf
7.2	Travel 行程	<p>Operate the keystone of the switch vertically, the travel distance of keystone moving from its free position to maximum moving distance shall be measurement.</p> <p>垂直操作开关按键，量测开关顶端最大移动距离。</p>	<p>travel:</p> <p>行程 0.35±0.15mm</p>



7.3	Static Strength 静止强度	<p>A static load of 0.2Kgf shall be applied in the direction of button operation for a period of 60 seconds. 在手柄动作方向施加 0.2kgf 的静负荷 60 秒，然后测试参数。</p>		No damage (Electrical And mechanical) 电气和机械性能正常.
7.4	Stem Pull Strength 手柄拉拔强度	<p>Break by a pull force applied opposite to the direction of stem operation. 在推柄动作方向反向垂直施加拉力，使其破坏的程度.</p>	500gf Min	
7.5	Shock 机械冲击	<p>Measured by according to the below condition: (1) Acceleration: 80g 加速度 (2) Cycles of test:3 cycles each in 6 directions, for a total of 18 cycles. 试验次数：每个方向 3 次，6 个方向共 18 次.</p>		Shall meet No.6, 7.1, 7.2. 满足 6, 7.1, 7.2 要求.



7.6	Life Test 寿命测试	<p>(1) Weight:120gf 砝码: 120gf</p> <p>(2) Operation speed: 60cycles/minute 操作速度: 60 次/分钟</p> <p>(3) Push force: Maximum value of operation force. 按压力: 操作力规格值的上限.</p> <p>(4) Cycles: 1,000,000 times Min 操作次数: 1,000,000 次以上(最小)</p>	<p>Contact resistance: 10 Ω Max 接触电阻: 10 欧以下</p> <p>Bouncing: 10ms Max 触点抖动: 10 毫秒以下</p> <p>Operation force: Variation rate within ±30% 操作力的变化范围在初始值的±30%以内.</p>
-----	-------------------	---	--

8.Environmental Performance/环境性能

Item 项目	Description 项目描述	Test Condition 测试条件	Requirement 规格要求												
8.1	Cold test 耐寒性	<p>(1) Temperature : - 20±2℃ 温度: - 20±2℃</p> <p>(2) Duration of test: 96h 持续时间: 96 小时</p> <p>(3) Take off a drop water 去掉水珠</p> <p>(4) Standard conditions after test : 1h 试验后的放置条件: 1 小时</p>	<p>Contact resistance: 200m Ω Max Shall meet : No. 6.2 to 6.4 No. 7.1 to 7.2 接触电阻 200m Ω 以下 满足: No. 6.2 to 6.4 No. 7.1 to 7.2</p>												
8.2	Heat test 耐热性	<p>(1) Temperature : 80±2℃ 温度: 80±2℃</p> <p>(2) Duration of test: 96h 持续时间: 96 小时</p> <p>(3) Take off a drop water 去掉水珠</p> <p>(4) Standard conditions after test : 1h 试验后的放置条件: 1 小时</p>	<p>Contact resistance: 200m Ω Max Shall meet : No. 6.2 to 6.4 No. 7.1 to 7.2 接触电阻 200m Ω 以下 满足: No. 6.2 to 6.4 No. 7.1 to 7.2</p>												
8.3	Temperature cycle 温度循环	<p>(1) Test cycles: 5 cycles 试验周期: 5 个周期</p> <p>(2) Standard condition after test:1h 试验后的放置条件: 1 小时</p> <table border="1" style="width: 100%; border-collapse: collapse;"> <thead> <tr> <th></th> <th>Temperature 温度</th> <th>Duration of test 持续时间</th> </tr> </thead> <tbody> <tr> <td rowspan="4" style="text-align: center;">1 cycle 一次循环</td> <td style="text-align: center;">20±5℃</td> <td style="text-align: center;">1h</td> </tr> <tr> <td style="text-align: center;">-20±2℃</td> <td style="text-align: center;">1h</td> </tr> <tr> <td style="text-align: center;">20±5℃</td> <td style="text-align: center;">1h</td> </tr> <tr> <td style="text-align: center;">70±5℃</td> <td style="text-align: center;">1h</td> </tr> </tbody> </table>		Temperature 温度	Duration of test 持续时间	1 cycle 一次循环	20±5℃	1h	-20±2℃	1h	20±5℃	1h	70±5℃	1h	<p>Contact resistance: 200m Ω Max Shall meet : No. 6.2 to 6.4 No. 7.1 to 7.2 接触电阻 200m Ω 以下 满足: No. 6.2 to 6.4 No. 7.1 to 7.2</p>
	Temperature 温度	Duration of test 持续时间													
1 cycle 一次循环	20±5℃	1h													
	-20±2℃	1h													
	20±5℃	1h													
	70±5℃	1h													

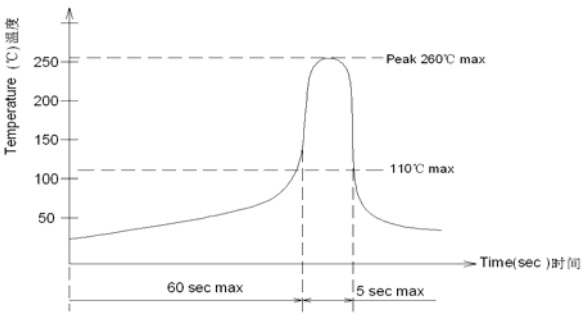

8.4	Soldering heat test 耐焊接热	<p>Soldering area: T/2 of PWB thickness. (PWB: T=1.6mm) 焊接面积: 印刷基板的 1/2 厚度处</p> <p>Soldering temperature: 260±5°C 焊接温度: 260±5°C</p> <p>Soldering time: 3±0.5s 焊接时间: 3±0.5 秒</p>	Appearance: No abnormality. 外观无异常
8.5	Solderability 可焊性	<p>1. Hand soldering 手工焊接: Please practice according to below condition: (1) Soldering Temperature : 350±5°C 焊接温度: 350±5°C (2) Continual soldering time: 3±0.5s 连续焊接时间: 3±0.5 秒 (3) Capacity of soldering iron: ≤20w 电烙铁功率: 20 瓦以下</p> <p>2. Automatic PIP soldering 自动焊接: For the product of T/H, according to below condition:</p> 	At least 95% of surface area of immersed portion shall be covered by solder. 侵焊面积大于 95%以上.
8.6	Humidity test 耐湿性	<p>(1) Temperature : 60±2°C 温度: 60±2°C</p> <p>(2) relative humidity: 90~95% R.H. 相对湿度:90~95% R.H.</p> <p>(3) Duration of test: 96h 持续时间: 96 小时</p> <p>(4) Take off a drop water 去掉水珠</p> <p>(5) Standard conditions after test: 1h 试验后的放置条件: 1 小时</p>	Contact resistance: 200mΩ Max Shall meet : No. 6.2 to 6.4 No. 7.1 to 7.2 接触电阻 200mΩ 以下 满足: No. 6.2 to 6.4 No. 7.1 to 7.2



P/N: CTA403301D02	DOC. No.: KH-PS1609-09	Rev.: A	Page: 9/10
-----------------------------	----------------------------------	-------------------	----------------------

8.7	Salt Spray 盐雾测试	<p>Apply the following environment to test: 根据下列条件进行测试:</p> <p>(1) Temperature : 35±5℃ 温度: 35±5℃;</p> <p>(2) Salt water density: 5±1% 盐水浓度: 5±1%;</p> <p>(3) Duration: 24 hours 持续时间: 24 小时;</p> <p>(4) After test, the salt deposit shall be removed by running water. 实验后将盐沉积物用水冲掉</p>	<p>Appearance: No corrosion spot, no crack, no base plate naked. 外观: 无腐蚀点, 无裂纹, 无裸露基材.</p> <p>Contact Resistance: 200 mΩ Max 接触电阻: 200 毫欧以下</p>
8.8	Withstand K ₂ S 硫化测试	<p>Apply the following environment to test: 根据下列条件进行测试</p> <p>(1) Temperature: 35±5℃ 温度: 35±5℃</p> <p>(2) K₂S Density: 2%; 硫化钾浓度: 2%</p> <p>(3) Duration: 2 minute. 持续时间: 2 分钟</p>	<p>Appearance: No corrosion spot, no crack, no base plate naked. 外观: 无腐蚀点, 无裂纹, 无裸露基材.</p> <p>Contact Resistance: 200 mΩ Max 接触电阻: 200 毫欧以下</p>

9. Recommended PCB Layout 推荐的 PCB 安装焊盘规格

(Top View)
(Single face board T=1.6mm)

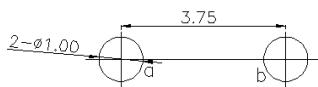

10. Packaging 包装

Packaging type: PE Bag, 1000Pcs/Bag, 20000Pcs/ Carton.

包装方式: PE 袋, 1000Pcs/袋. 20000Pcs/箱

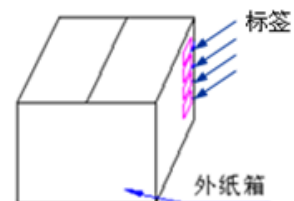
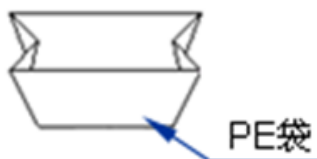



P/N: CTA403301D02	DOC. No.: KH-PS1609-09	Rev.: A	Page: 10/10
-----------------------------	----------------------------------	-------------------	-----------------------

11. Precaution 注意事项

11.1 Immersion Soldering condition 浸焊条件

ITEM 项目	CONDITION 条件
Preheat temperature 预热温度	110°C Max (Ambient temperature of soldering surface of P.W.B) 110°C 以下(印刷基板焊锡面周围的温度)
Preheat time 预热时间	60s, Max 60 秒以内
Area of flux 助焊剂面积	1/2 Max of PWB Thickness 印刷基板厚度的 1/2 以内
Temperature of solder 焊锡温度	260±5°C 260±5°C
Time of immersion 浸焊时间	Within 5s 5 秒以内
Number of soldering 焊接次数	2time Max (But should down heat of the first soldering) 2 次以内
Printed wiring board 印刷基板	Single side copper-clad laminates 单面铜箔

- (1) After switches were soldered, please be careful not to clean switches with solvent
开关浸焊后,注意不要用溶剂清洗.
- (2) Under the condition of using soldering iron, soldering temperature shall be 350°C ± 5°C max within 3 sec.
在使用烙铁的情况下,焊锡温度应在350°C ± 5°C,焊接时间3秒以内.

11.2 Notes 注意点

- (1) Please be cautious not to give excessive static load or shock to switches.
注意不要施加超负荷的压力或晃动开关.
- (2) Please be careful not to stack up P. W. B. after switches were soldered.
开关焊接以后,印刷基板注意不要叠放.
- (3) Preservation under high temperature and high humidity or corrosive gas should be avoided Especially. When you need to preserve for a long period, do not open the carton.
保管时尤其应注意避开高湿高温和有腐蚀性气体的环境.如需长时间保存,请不要打开包装箱.
- (4) Products meet the ROHS & REACH environmental management substances control standards
产品满足 **ROHS & REACH** 环境管理物质管制标准